

# Distribution tool for stepwise filling, suspended in rails

## CABINPLANT PRODUCT SHEET

Cabinplant's customized distribution tools are designed to receive weighed portions from a multihead weigher for distribution and filling into trays, cans, glass jars, cartons, bags etc. The tools are available for filling from 1 up to 2 x 4 at a time.

The distribution tool design ensures that the weldable edges on the tray are kept free of product to obtain the best possible result when welding the top foil onto the tray.

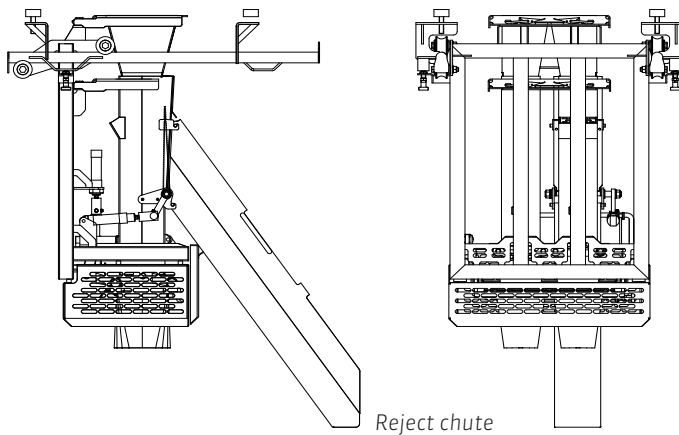

Capacity and dimensions	
Capacity	Up to 160 /min.*
Dimensions	Customized
Tray size	Customized

\* depending on product, packing materials and portion size



### Application

- Filling of products into trays formed by a thermoforming machine or into trays on a step conveyor. Cans, glass jars, boxes etc. will be filled in fixed positions.

### Functionality

- Fast and precise delivery of product from multihead weigher into packing materials
- To prevent waste the tools can be lowered into the trays
- Easy cleaning of the parts in contact with products
- Stand-alone electrical control system or integrated with CabinControl

### Advantages

- High speed
- Precise filling
- Clean tray edges
- Easy cleaning
- No product spillage
- By exchange of format parts different trays can be dosed from the filling tool
- Quick change of container size

**Cabinplant A/S**  
Roesbjergvej 9  
DK-5683 Haarby  
Denmark

Tel.: +45 6373 2020  
Fax: +45 6373 2000  
E-mail: [cpi@cabinplant.com](mailto:cpi@cabinplant.com)

[www.cabinplant.com](http://www.cabinplant.com)

**Cabinplant**  
Precise by nature