

Distribution tool for stepwise filling, mobile frame

CABINPLANT PRODUCT SHEET

Cabinplant's customized distribution tools are designed to receive weighed portions from a multihead weigher for distribution and filling into trays. The tools are available for filling 1 x 1 and up to 4 x 8 trays at a time. In case of product mixes, the distribution tools can handle up to 2 different types of product to be filled into trays in the same operation. The distribution tool design ensures that the weldable edges on the tray are kept free of product to obtain the best possible result when welding the top foil onto the tray.



Application

- Filling of products into trays formed by a thermoforming machine or into trays on a step conveyor

Functionality

- Fast and precise delivery of product from multihead weigher into trays
- The tools can be lowered into the trays, which prevents product on the weldable edges
- Integrated reject function
- Stand-alone electrical control system or integrated with CabinControl
- Solution with stamper can be incorporated

Advantages

- High speed
- Precise filling
- Clean tray edges
- No product spillage
- Easy cleaning
- Removable
- By exchange of format parts different trays can be dosed from the filling tool
- Quick change of container size

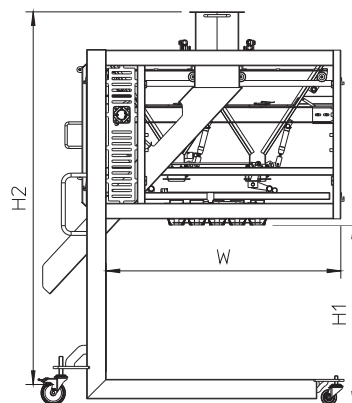
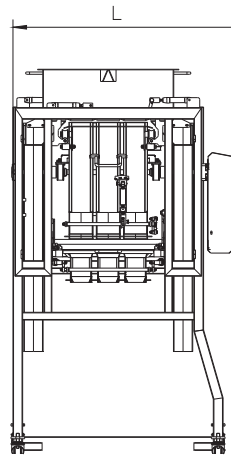
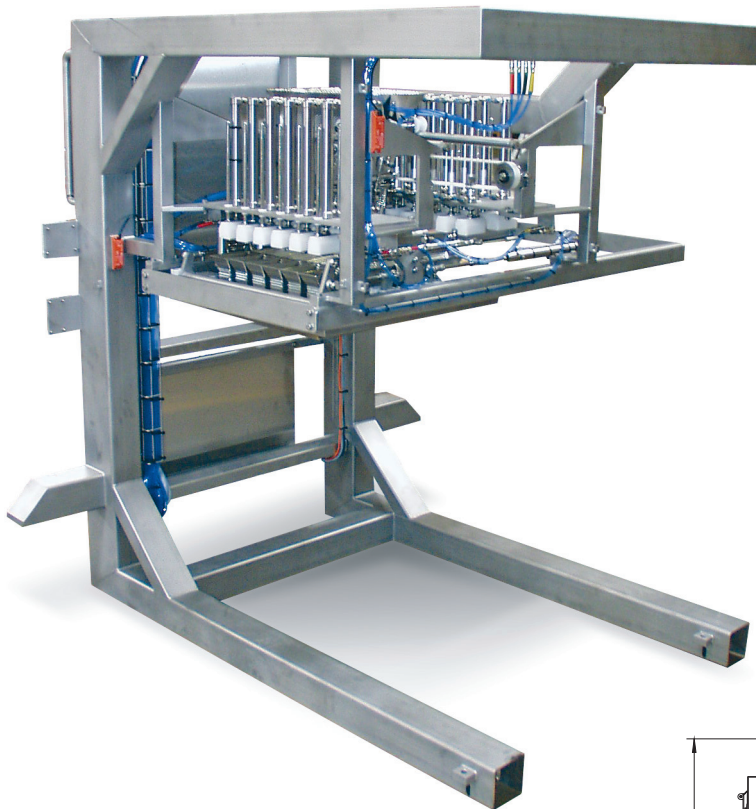

Capacity and dimensions	
Capacity: Up to 250/min.*	
Typical dimensions	mm
Length (L)	1100 - 1300
Width (W)	1000 - 1250
Height, total, adjustable (H2)	1800 - 2100
Height, conveyor, adjustable (H1)	850 - 950
Tray size	Customized

* depending on product, tray and portion size

Cabinplant A/S
Roesbjergvej 9
DK-5683 Haarby
Denmark

Tel.: +45 6373 2020
Fax: +45 6373 2000
E-mail: cpi@cabinplant.com

www.cabinplant.com

Cabinplant
Precise by nature