



Cutter

Bean



PRODUCT SHEET

Advantages

- Excellent cutting
- No blocking
- Easy to clean
- By-pass for whole bean production
- Exchangeable cutting tool
- Stainless steel machine
- Central greasing system
- SEW gear motor
- JVM vibrator
- Gentle product handling

Cabinplant A/S
Roesbjergvej 9
DK-5683 Haarby
Denmark
Tel. : +45 6373 2020
Fax : +45 6373 2000
E-mail : cpi@cabinplant.com

www.cabinplant.com

Cabinplant
Precise by nature

Predefined cutting of beans

Cabinplant's bean cutting machine is designed to cut green beans into predefined lengths.

The beans are fed from the integrated vibrator, where they are orientated longitudinally to ensure correct feeding to cutting tools.

The cutting tools are equipped with a number of knives and knife cutting bases. The beans are cut in predefined lengths, defined by the cutting tool.

Various cutting tools: 13, 16, 25, 30, 32, 39 mm - other tools on request.

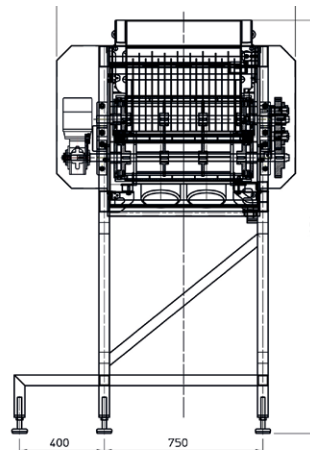
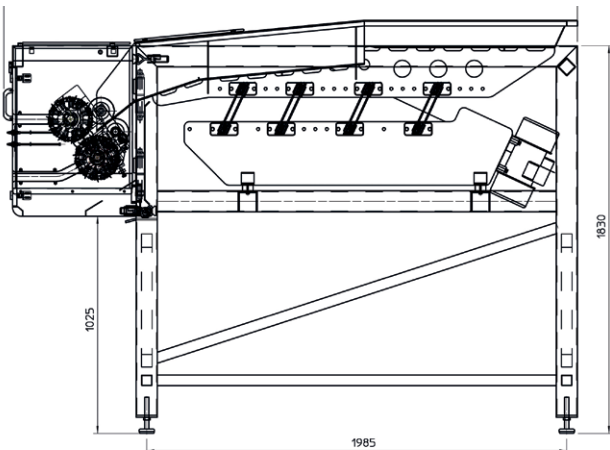
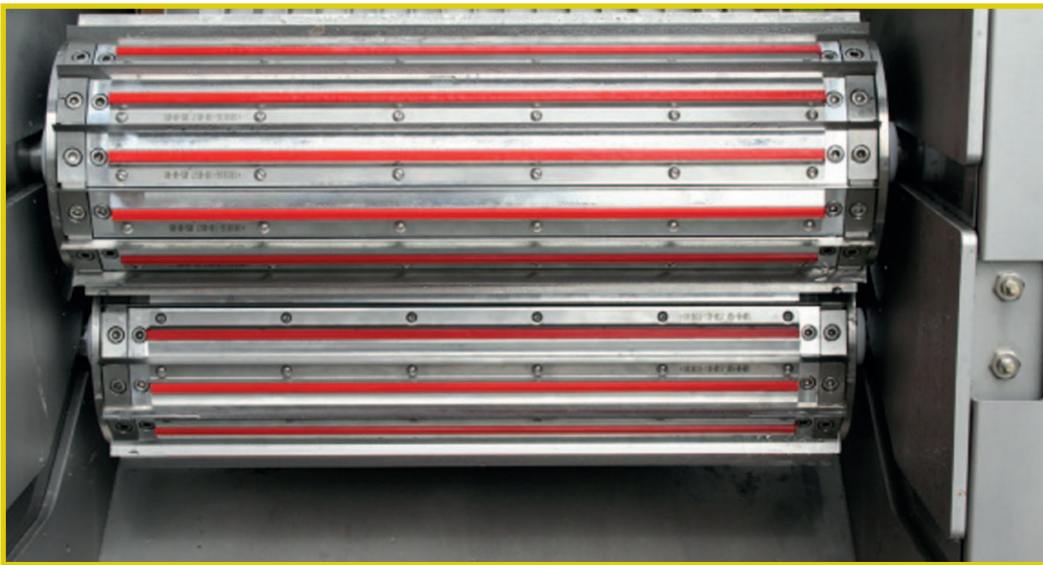
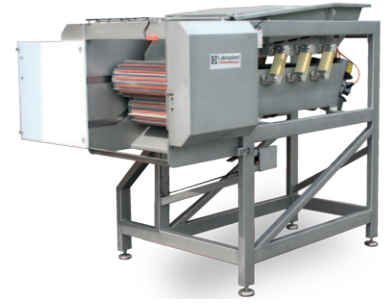

Application

- Green beans (round or flat)

Functionality

- Longitudinally oriented beans are being fed to two synchronously counter-rotating knife drums which cut the beans.
- Vibrator infeed system

Capacity			
Volume	t/hour	3.5	

Dimensions				
	mm	Length	Height	Width
Bean cutter		2100	1830	1150

Measures may vary depending on type of use