

Technical data

Type	FS-3600/Multicut
Voltage	230/400 V, 50/60 Hz
Installed power	1.6 hp
Dimension (LxWxH)	7ft 7.8" x 4ft 5.6"x 5ft 10.1"
Total weight	approx. 1,100 lbs (including conveyor belt)
Belt width	6.3"

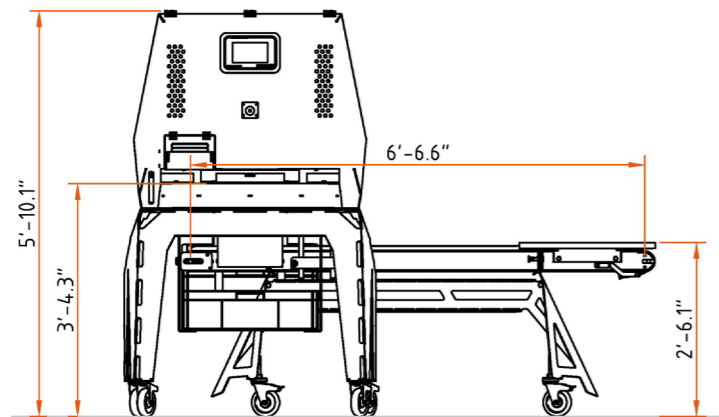

Slice and wedge cutter **FS-3600/Multicut**

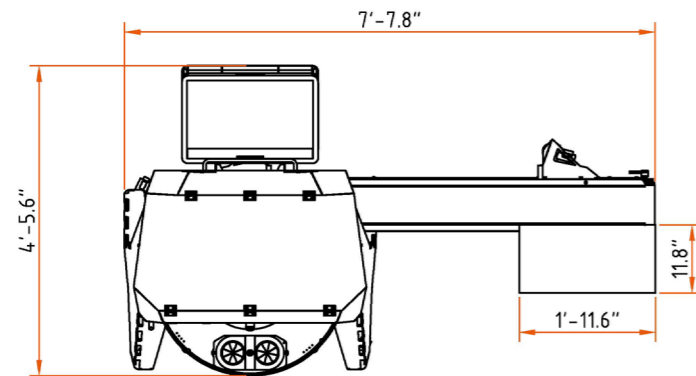

Operating principle

The Sormac slice and wedge cutter type FS-3600/Multicut cuts fruit and vegetables into wedges, slices or sticks. The design of the machine has been specially developed to meet the requirements of the food processing industry.

Depending on the size, the slice and wedge cutter can cut up to two products in one cutting movement. This requires the products to be placed in the holding devices of the rotary table. The rotary table consists of four holding devices which take the product directly to the fixed cutting unit. The rotary table, which is driven by a servo motor, is rotating clockwise.

The high-quality knives are placed in a knife cassette which features a quick-change system, which makes changing and cleaning the knives easier.

Cut products are transported to one side of the machine by a conveyor belt, which can be set to continuous or intermittent mode. The products are collected there for further processing, or packaging. Cores and end slices can be separated from the finished product.

Capacity

The maximum capacity of the semi-automatic slice and wedge cutter type FS-3600/Multicut for fruits and vegetables is up to 3,600 pieces per hour.

Advantages

- various cutting shapes: wedges, slices, sticks
- perfect cutting results with a straight cut edge
- electrically driven cutting unit
- adjustable speed
- low maintenance
- easy to clean



Hygienic and accessible design

The wing doors on the front and back, as well as the swivelling control cabinet, facilitate cleaning of the interior space.

Electrically driven punching mechanism

Because the punching mechanism is driven by an electric motor, continuous pressure is applied to the product. This results in a perfect cut and high punching performance of up to 3,600 units/hour.

Double product holder system

Depending on the size of the product, 2 products can be cut in one cutting movement. Four product holder systems are attached to the rotary table, which carry the product to the secured punching unit.



Box holder (optional)

A box can be placed in the box holder to collect cutting waste.

Packing table (optional)

Table suitable for quick and easy packing of the cut product.

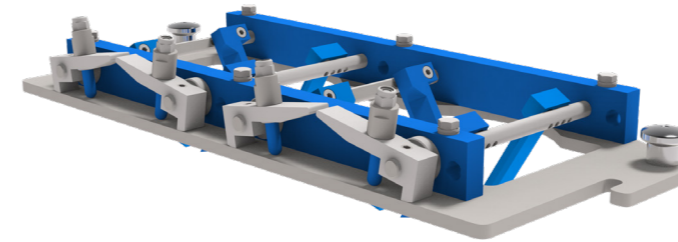

Funnels with waste separators

Various funnels are provided to separate waste from the cut product. These direct the waste to a crate.

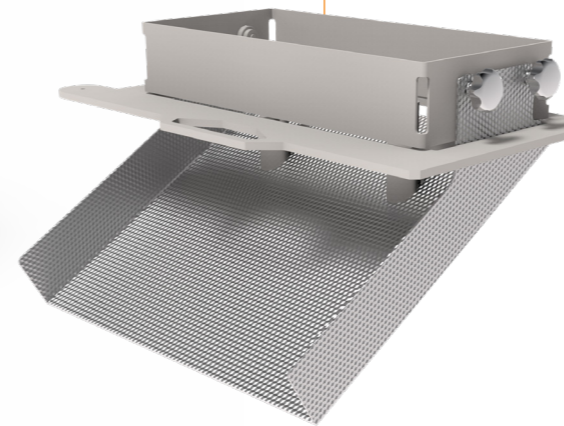

Tool trolley (optional)

For organized storage of the knife units, ejectors and funnels.

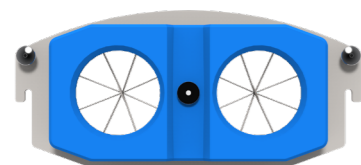

Wedge cutter

- 4, 6, 8, 12 or 16 wedges
- Suitable for various types of fruit

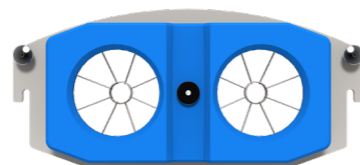

Wedge cutter with de-corer

- 4, 6, 8, 12 or 16 wedges
- Corer 0.79", 0.98" and 1.18"
- Suitable for apples and similar

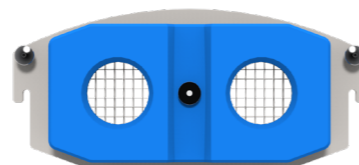

Stick cutter

- 0.39", 0.59" or 0.79" grid
- Suitable for (sweet) potatoes

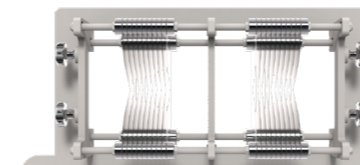

Knife unit for slices

- 5-10 mm (per 0.5 mm)
- Suitable for a variety of fruit and vegetables

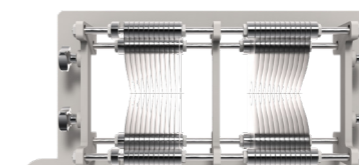

Knife unit for half slices

- 0.2"-0.39" (per 0.19")
- Suitable for a variety of fruit and vegetables

Different knife variations

Various knife units are available for cutting wedges, (half) slices or sticks. All knife variations are made of stainless steel in combination with plastic (suitable for the food processing industry). A quick-change system facilitates changing and cleaning of the knife units.