

Manual slice and wedge cutter F-1000



Operating principle

The Sormac manual slice and wedge cutter F-1000 is offered in various models.

The F-1000 is the smallest manual wedge cutter and especially designed for cutting products into wedges. The F-1000L and F-1000XL can also cut product into slices or sticks.

Because of their robust construction, they are especially designed for constant use. Applied knives are characterized by their high cutting quality as well as their great durability.

The slice and wedge knives are completely made of stainless steel. Pushers and guide rollers are made of synthetic and stainless steel, which is approved for direct contact with food products.

Capacity

The capacity of the manual slice and wedge cutter type F-1000 for fruits and vegetables are up to 600 pieces per hour.

Features

- various cutting variations: wedges, slices, sticks
- end piece and core separation
- perfect cutting result
- applicable to a large range of products
- robust construction
- low maintenance
- easy to clean



Product specification

The Sormac serie of F-1000 manual slice and wedge cutters have their own product specification, as follows:

- F-1000: for cutting products with a maximum diameter of 95 mm into wedges.
- F-1000L: for cutting products with a maximum diameter of 150 mm into wedges and products with a maximum diameter of 110 mm and a maximum length of 150 mm into slices or sticks.
- F-1000XL: for cutting products with a maximum diameter of 150 mm into wedges and products with a maximum diameter of 120 mm and a maximum length of 220 mm into slices or sticks.

Technical data

Type	F-1000	F-1000L	F-1000XL
Dimensions (LxWxH)	645 x 395 x 1,230 mm	535 x 395 x 1,120 mm	535 x 455 x 1,125 mm
Available cuts *	2, 4, 6, 8, 10, 12, 16 wedges	2, 4, 6, 8, 10, 12, 16 wedges 4,5 - 30 mm slices 8 - 40 mm sticks	2, 4, 6, 8, 10, 12, 16 wedges 4,5 - 30 mm slices 8 - 40 mm sticks

* Depending on product

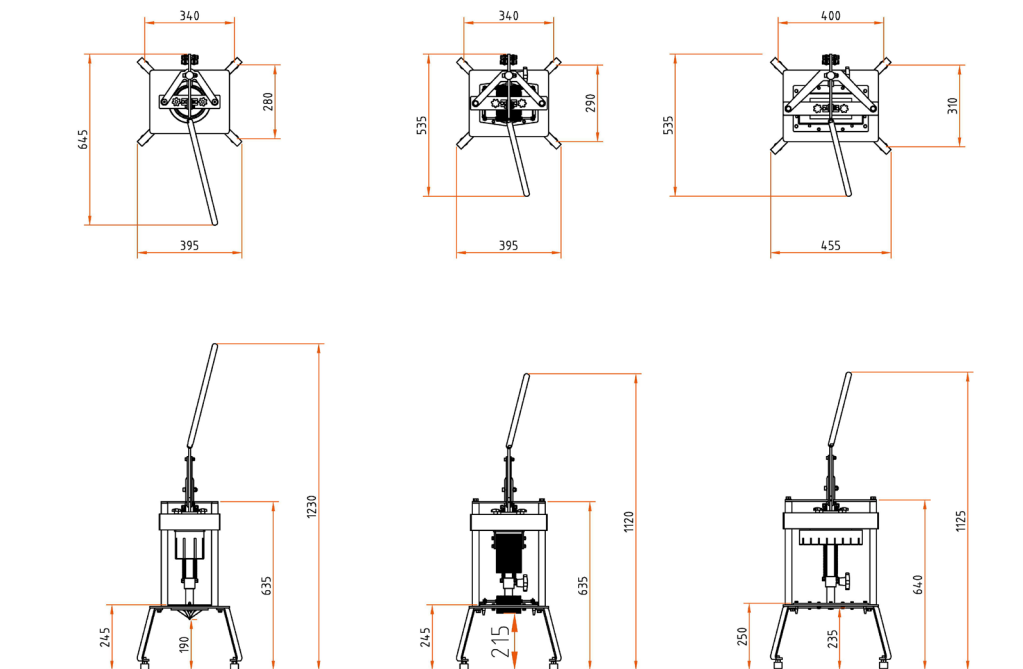

Sormac B.V.

P.O. Box 419
NL-5900 AK Venlo
Huiskensstraat 68
NL-5916 PN Venlo

T: +31 (0)77 351 84 44
F: +31 (0)77 320 48 01
info@sormac.nl
www.sormac.nl

Subject to changes