

Potato halving machine DMC-60



Operating principle

Sormac potato positioning and halving system to divide into 2 pieces.

On the rollerbed the potatoes are lined up on to six parallel rows and transported to the cutting section. A set of 6 pieces rotating circular knives divide the potatoes in 2 pieces. The rollers are driven by a stainless steel chain which is fixed on both sides and connected to a frequency-controlled motor. For equal line up of the potatoes and an optimal filling of the position rollers, the machine is equipped with a vibration chute.

The machine is fitted on a frame and supports with adjustable legs. The casing for the drive and cutting sections has hinges. The side plates of the roller bed and the drive chain can be easily disassembled.

The electrical control panel is fixed to the body of the machine and provided with all switching and safety equipment, frequency controllers and operating buttons.

Capacity

Approx. 30.000 potatoes per hour (theoretical 48.000 pcs/hr.).

Scope of supply

- > control panel
- > frequency controlled drive motors
- > vibration chute
- > machine safeties

Features

- > long shelf life
- > hygienic design
- > simple operation
- > durable, hard-wearing and reliable
- > ease of access

Product specification

The maximum product length is 90 mm
and the diameter 40 - 55 mm.

Technical data

Voltage:	230/400 V,50/60 Hz
Total installed power:	0.75 kW
Noise level:	< 75 dB(A)
Weight:	690 kg
Dimensions (LxWxH):	approx. 2.820 x 1.330 x 1.690 mm

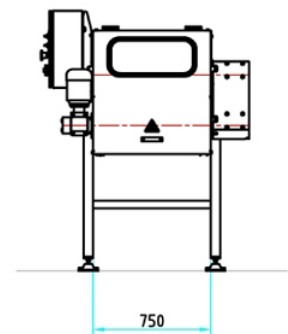
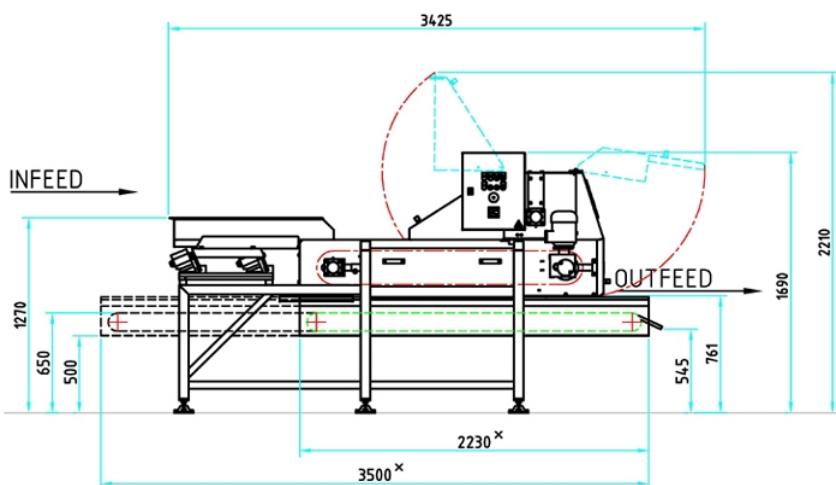
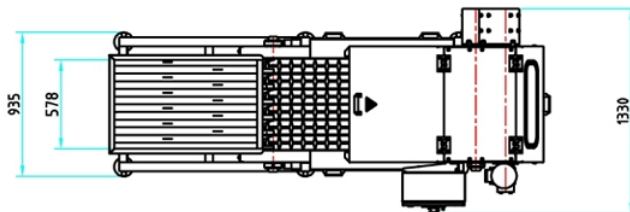
**Sormac B.V.**

P.O. Box 419
NL-5900 AK Venlo

Telephone: +31 (0)77 351 84 44
Fax: +31 (0)77 320 48 01

Huiskensstraat 68
NL-5916 PN Venlo

E-mail: info@sormac.nl
Internet: www.sormac.nl

Alterations reserved