



# AUTOMATIC LINEAR CAPPING MACHINE GG250



The machine, manufactured in stainless steel and complying with CE regulations, has been designed for the closing of jars and/or bottles with metal twist-off caps.



Capping operation executed in a saturated steam chamber with high vacuum in the container. Constant vacuum value. Equipped with the suitable optional sets of change parts, the machine can handle metal caps type: Regular, Medium, Deep Twist-Off, Pry-Twist, Pry-Off ranging between  $\varnothing 27 \div 110\text{mm}$  and H.  $5 \div 19\text{mm}$  and containers  $\varnothing 30 \div 160\text{mm}$  / H  $50 \div 260\text{mm}$

The machine is supplied with the magnetic cap feeder at floor level GG900, which can be installed at a distance to reduce noise significantly.



## AUTOMATIC LINEAR CAPPING MACHINE GG250

### ADVANTAGES

- Stainless steel construction
- High hygiene and sanitation
- easy adjustment to different sizes with no need of special change parts, even with the machine in production
- constant screwing strength in any working conditions
- quick format change-over
- high resistance to corrosion
- easy cleaning and maintenance.

### APPROX. TECHNICAL FEATURES

- Motor power : 3,25 kW
- Steam consumption : 100kg/h a 3 bar
- Air consumption : 5 NI/1'' at machine start – pressure at 6 bar
- Water consumption : 20l/h at 2 bar 8 -10° french degrees
- Overall dimensions : 4000 x 1000 x h 2400mm
- Weight : 700 kg (without cap feeder)
- Max speed. 30,000 cph with RTO Ø 38mm cap size

*This technical sheet gives an approximate description of the machine.  
The technical features and the machine configuration are to be confirmed at the time of order.*

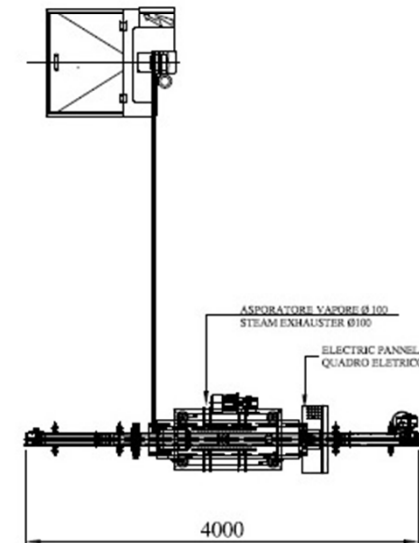
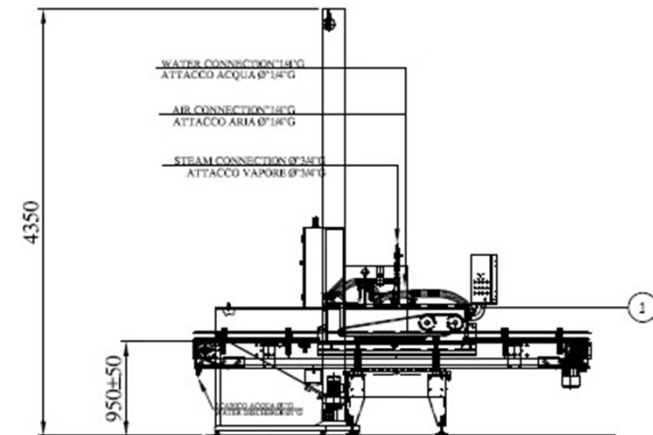

**UNIMAC-GHERRI SRL**

- Strada Barco 4/G - 42027 Montecchio Emilia (RE) ITALY -

Tel. +39 0522 863046 - Fax +39 0522 864211 E-mail: info@uni-mac.com www.unimac-gherri.com